

SCALES

HANGING DIAL SCALES



15" DIAL FACE

- Legal for trade
- Dial chart: 10 lbs x 1 oz
- Capacity: 30 lbs (3 revolutions)
- 15" stainless steel pan



T3530 Double Face (read from both sides)

8" DIAL FACE

- Dial chart: 10 lbs. x 1 oz
- Capacity: 20 lbs. (2 revolutions)
- 12" stainless steel pan
- Holes for drainage



MCS20F Single Face
MCS20FD Double Face (read from both sides)

SCALE HANGERS

- Stainless steel
- Mounting brackets included

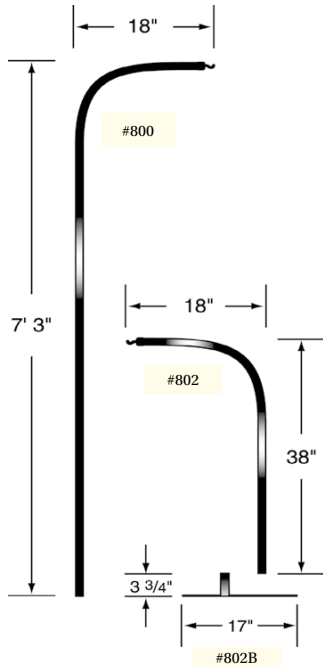

800 7' 3"
802 38"
802B Mounting Base

PORTIONING SCALES

DIGITAL CAS

- Legal for trade
- Stainless steel platter
- Large 1" LCD display
- Toggles between lbs/kg/oz./k
- Battery operated (6 "D" batteries)
- AC adapter included
- Plate size: 9" x 7½"
- Overall dimensions: 10¹³/₆₄" x 11⁹/₆₄" x 5²⁵/₆₄"



Item Number	Capacity	Minimum Division
SW5	5 lbs002 lbs
SW10	10 lbs005 lbs
SW20	20 lbs01 lbs

SPRING DIAL SCALES

- Stainless steel platform (9" x 9")
- 8" dial face
- Dimensions: 9¾" x 6¾" x 10¾"
- USDA approved



STAINLESS STEEL CASE

LCD3218	32 oz. x 1/8 oz
LCD0512	5 lbs. x 1/2 oz
LCD1001	10 lbs. x 1 oz
LCD4002	40 lbs. x 2 oz

- Stainless steel platform (5¾" x 5¾")
- 6" dial face
- Rotating dial
- Dimensions: 7¾" x 5½" x 7¾"



BROWN ENAMEL CASE

FS3214R	32 oz x 1/4 oz
FS0512R	5 lbs x 1/2 oz

BOWL SCALES

- 8" dial face
- 10¾" diameter x 2" stainless steel bowl
- Overall dimensions: 9¾" x 6¾" x 12¼"



STAINLESS STEEL

LCD2001SBA	20 lbs x 1 oz
LCD4002SBA	40 lbs x 2 oz

BROWN ENAMEL

LCD2001BA	20 lbs x 1 oz
LCD4002BA	40 lbs x 2 oz



SCALES

WATER RESISTANT LCD DISPLAY



- Stainless steel
- Ideal for humid environments
- Portable - scales will operate anywhere with a long lasting rechargeable battery (approx. 90 hours)
- Capacity: 50 kg/100 lbs
- Display: 0.01 kg/0.02 lb
- Plate dimension: 19" x 15"

EQB50/100W 21" x 19" x 24"

- Capacity: 20 kg/40 lbs
- Display: 0.005 kg/0.01 lb
- Plate Dimension: 15" x 12"



EQB20/40W 18" x 15" x 19½"

EPOXY FINISH



- Capacity: 50 kg/100 lbs
- Display: 0.01 kg/0.02 lb
- Plate dimension: 19" x 15"

EQB50/100 25½" x 15" x 23½"

CAS LABELS FOR MODEL LP1000

(Scale not shown)

Sold by the case. 12 rolls per case.

Item Number	Size	Description	Qty per Roll
LST8000	58 mm x 30 mm	Non-UPC	1000
LST8010	58 mm x 40 mm	UPC	700
LST8020	58 mm x 60 mm	UPC/Ingredient	500
LST8030	58 mm x 50 mm	Non-UPC /Safe Handling	600
LST8040	58 mm x 60 mm	UPC/Safe Handling	500

CAS

- Legal for trade
- 3 direct PLU & 199 indirect PLU's
- Rechargeable battery (LCD type)
- Auto power off
- kg/lb switchable
- Backlit LCD
- Capacity: 30 x .01 lbs

COMPUTING SCALES

PRICE COMPUTING SCALE



Complete spec sheets available on request

S2000JR30 13³⁷/₆₄" x 12⁵⁷/₆₄" x 4¹³/₆₄"

DLP50 Label Printer for S200JR Scale (sold separately)

LST8060 Labels

LABEL PRINTING SCALE



- Legal for trade
- Stainless steel
- 300 PLU memory
- Thermal printing
- 72 direct access keys
- 110V
- Capacity: 40 lbs. x .01 lbs.

LSQ40L 19½" x 17²¹/₃₂" x 21"

LABELS FOR MODEL LSQ40L

Sold by the case. 12 rolls per case.

Item Number	Size	Description	Qty per Roll
LSTT101B	58 mm x 40 mm	Blank	1000
LSTT113B	58 mm x 60 mm	Blank	1000
LSTT113S	58 mm x 60 mm	Safe Handling	1000
LSTT120	58 mm x 2475"	Blank	Continuous Strip

MOBILE PLATFORM SCALES



- Capacity: 200 kg/400 lbs
- Display: 0.05 kg/0.1 lb
- Plate dimension: 32¼" x 32¾"

EQM200/400 38" x 32¼" x 42½"

- Capacity: 400 kg/800 lbs
- Display: 0.1 kg/0.2 lb
- Plate Dimension: 32¼" x 32¾"

EQM400/800 38" x 32¼" x 42½"

RECEIVING/UTILITY SCALE

- Stainless steel
- Shatter proof lens
- Non-skid rubber feet
- Capacity: 250 lbs x 1 lb

PS250SS 13½" x 12½" x 3½"

